

Quality and versatility.

All of Schaerer's best-in-cup quality, and all the flexibility in terms of drinks variety and machine portability.

From office-hero to star of the party.

Install it as a fixed coffee station by connecting it to the water mains, or take it just about anywhere thanks to its internal water tank.



Schaerer Coffee Skye.

*Take the Schaerer quality and variety anywhere you need to.
Serve delicious coffee and milk based specialties virtually everywhere.*



Versatility and style, everywhere.

Stylish and attractive, the new Schaerer Coffee Skye was designed for maximum flexibility as a fixed-station or mobile machine, offering great variety and uncompromising quality.



Its 4.9 litres internal water tank allows you to use it just about anywhere: in outdoors settings, on a terrace or in a conference room. Alternatively, connect it to the water mains, customise it with a choice of accessories and add-ons, and turn it into a permanent office landmark

for the most satisfying coffee-break in town! Its appealing design, its variety of coffee and milk-based specialties and its solid performance combined with great ease-of-use, make it the ideal choice for flexibility and quality.



An elegant design, highlighted by stylish detailing.

With its refined all-black livery, enhanced by red or black design elements, it will stand out in any situation as a stylish element of your setup. Whatever the scenario, Schaerer Coffee Skye perfectly adapts to your needs with striking natural elegance. The machine is conceived for efficiency and ease of use by staff or self-serving guests, whatever their level of proficiency.

Ideal for...

Small and medium-sized restaurants and hotels; offices; bakeries; convenience stores; self-service shops; petrol stations; catering operations as well as all locations that have limited space. Designed for ease of use, Schaerer Coffee Skye can adapt to all kinds of users, from first-timers self-serving guests to experienced staff thanks to 3 operating modes. Its wide 8" touch screen display is video enabled and can feature your regular promotions and advertisements.





Eclectic, Easygoing, Entertaining, Eventful. The new Schaefer Coffee Skye has a sparkling personality and is really versatile, stealing the show wherever you decide to use it, offering a great variety of delicious drinks and uncompromising quality.

Standard configuration.

An effective and comprehensive setup for your Coffee Skye, getting you ready to start delivering a variety of top quality coffee and milk based beverages.



The ideal all-rounder kit.

A solid performer with high daily/hourly output, Coffee Skye features a newly designed hopper with easy lock-on/off and a manual inlet for decaf or other blends.



Functional illumination

Colour-coded functional lights, on either side of the central outlet, indicate the status of the machine:

White - Machine ready

Yellow - Intervention required soon (refilling, cleaning, etc.)

Red - Machine error (milk empty, grinder blocked, water flow error, etc.)



Asymmetrical and monitored drip tray

750 ml drip tray with tray presence and fill level sensor for overflow protection. Tray is cut-out for easy removal and features handy cup positioner for smooth self-service operation. Closed tray or drain options available.



Internal water tank

The 4.9 litres internal water tank makes Schaefer Coffee Skye totally independent from the mains water supply, offering great flexibility in the positioning of your coffee station.





8" touch screen display

The wide, 8" display has a resolution of 1024x768 pixels and offers a rewarding and satisfying user experience. Coffee Skye's user interface features 3 integrated operation modes: Guest, Frequent user and Staff, for total ease of use whatever the level of proficiency. The screen is video enabled for you to run any promotion or advertisement easily and effectively.

Open up to a world of variety.

With Schaerer Coffee Skye's numerous options and accessories, upgrade your standard offer and easily adapt your machine to your evolving needs.



Customise your Coffee Skye to fit your style and delight your guests.

Customise your Coffee Skye to fit your style and delight your guests.

Boost your milk-based beverages offer with the **Pure Foam** pumped-milk system. Choose between cold or hot milk, or an enticing, homogeneous, creamy

and fine pored foam - up to 60% foam content - for extra pleasure and variety. The system is also very easy to rinse and clean. Add a separate hot water outlet for teas and infusions, or a **Powersteam** wand for that perfect Italian cappuc-

cino or latte macchiato. Choose from the many other options and add-ons available to create your ideal work tool, perfectly adapted to your requirements and your personality.

Elegance and ease-of-use are the hallmark of the new Schaerer Coffee Skye.



Easy water.

No need to fill-up nor think about your water level: connect your Coffee Skye to the water mains, as an option, and set it up as a permanent location coffee station. The connection setup includes Schaerer's Uptime! system for top quality, scale-free water.

More hoppers, more choice.

Add another bean hopper and extra grinder alongside your standard central one, and complete your set with a single 2000g or twin 2x1000g powder hopper with a separate preparation system. Boost the variety of your offer with a number of delicious specialties. The new locking system makes it incredibly simple to insert and remove the hoppers instantly.

Milk hose openings on both sides.

Whatever the layout of your coffee station, the handy extra large openings on either side of your Schaerer Coffee Skye will make it easy to connect any external milk cooler. The hatches integrate seamlessly and elegantly into the design of the machine, while contributing to its versatility and functionality.

Simplified installation.

Installing your new Schaerer Coffee Skye has never been so easy. All the connections required for the installation are accessible from the front. No tools are required to remove the connection piece for the waste water hose. Simple hose mounting for the under-counter device, without disassembling the side walls.

Standard equipment, options, accessories.

STANDARD EQUIPMENT:



8.0" touch screen display

Video capable 1024x768 px high resolution screen with three integrated operation modes: Guest mode, Frequent user mode and Staff mode.



Single grinder

750 g top mounting bean hopper with manual inlet hatch for decaf and other blends.



Hot water on the left

A separate hot water outlet on the left for tea and other beverages. Particularly suited for service areas.



Functional illumination

Functional status lights placed on both side of the central outlet.

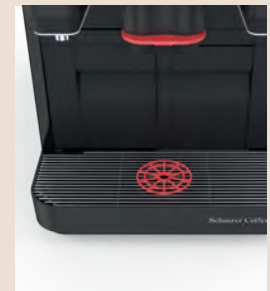

Black housing and splash zone

Elegant all-black livery for machine body and splash zone, with refined red/black detailing.

OPTIONAL FEATURES:



Manual outlet

Manual outlet with single/double coffee spout including relief chamber. Manually adjustable height from 65 mm to 185 mm.



Internal water tank

4.9 l capacity internal water tank, with closed and monitored drip tray.



Pure Foam milk system

Preparation of temperature-controlled hot milk & hot milk foam, as well as cold milk for variety of beverage options.



Up to 2 grinders

Add a second grinder and 750 g bean hopper to offer variety of coffee blends.

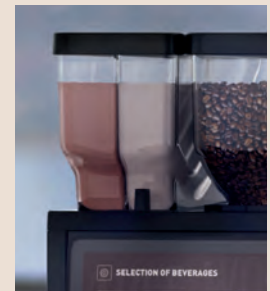

Single/twin powder

Add single 2000 g or twin 2x1000 g topping powder hopper for extra variety of beverage options.



Schaerer Coffee Link: your digital intelligence

Schaerer Coffee Link is a digital service platform providing a powerful, real-time tool for the monitoring and the optimisation of your coffee operation.

> OPTIONAL FEATURES:



Central hot water outlet

Central outlet doubles as hot water dispenser for teas and infusions.



Powersteam on the right

Without monitoring, the foam consistency and temperature must be checked manually. Perfect for locations with a professional Barista.

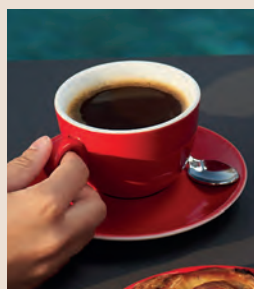

Brewing accelerator or additional water

Extra efficiency during peak hours and better quality in large servings beverages (e.g. Americano).

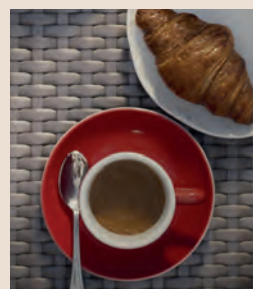

Espresso blades

Add special espresso blades to any of the two grinders, or both, for that real Italian feel.



Electrical adjustment per grinder

Grinders can each be electrically adjusted according to preferences and bean type.

ACCESSORIES:



Under-counter grounds disposal

Expands ground-cakes disposal capacity, and machine autonomy, whilst freeing up counter space.

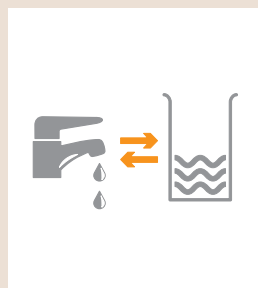

Fixed water connection with Uptime!

Connect your machine to mains water supply. Includes Schaefer's Uptime! system.



Under-counter cooling unit

Featuring 10 l milk container which can be placed under the counter to save space.



Payment systems

Standard payment systems as per MDB standard. The coin changer, card reader, etc. can be easily connected to the coffee machine.



Side cooling unit

The external cooling unit allows to store up to 10 litres of fresh milk. This cooling unit can be lodged in some spare space on the side or under the counter.

Configuration and technical data.

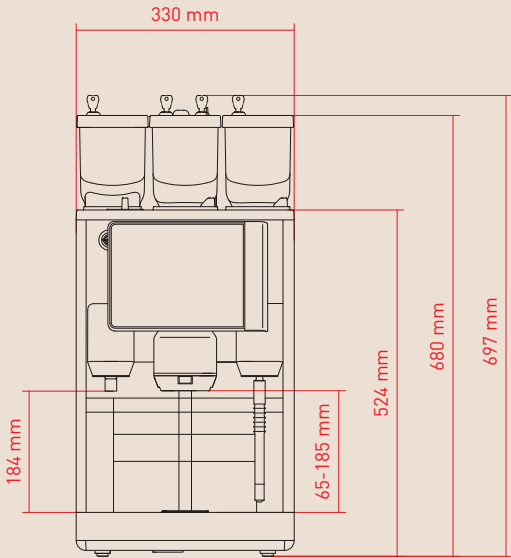

Schaerer Coffee Skye
frontal view

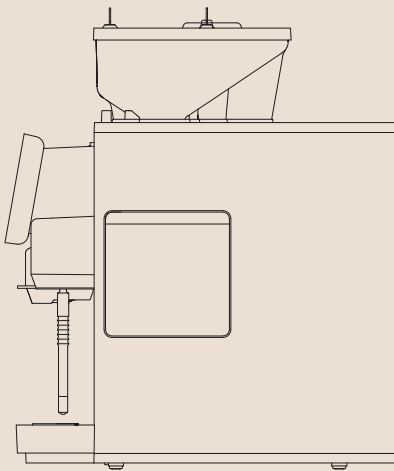

Schaerer Coffee Skye
left side view

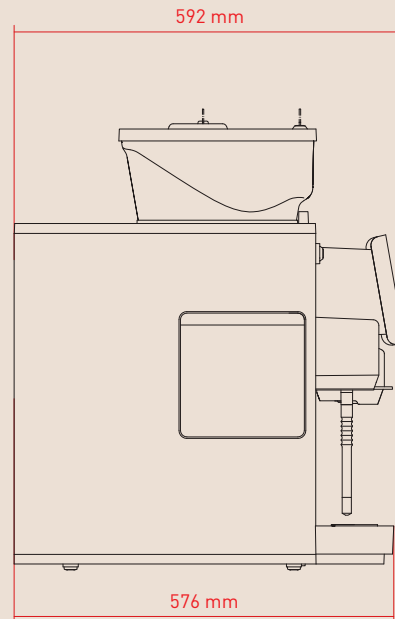

Schaerer Coffee Skye
right side view

| Category | Equipment and options | Schaerer Coffee Skye |
|---------------------------|---|--|
| Output per day | Recommended for an average daily requirement of | Up to 180 |
| Range of beverages | Espresso | s |
| | Coffee/café crème | s |
| | Cappuccino | o |
| | Hot water | s |
| | Ristretto | s |
| | Small pot (250 ml) | s |
| | Pot (500 ml) | s |
| | Americano | o |
| | White Americano | o |
| | Milk coffee/latte | o |
| | Latte macchiato | o |
| | Espresso macchiato | o |
| | Chociatto | o |
| | Hot chocolate | o |
| | Flat white | o |
| | Instant (e.g. chai latte) | o |
| | Cold milk | o |
| | Hot milk | o |
| | Hot milk foam | o |
| Steam | o | |
| Powder-based beverages | o | |
| Operation and dispensing | 8.0" screen Touch User Interface | s |
| | 3 different operation modes: guest (self-service), frequent user (quick self-service), staff (operated) | s |
| | Number of beverages possible (programmable) | > 100 |
| | Outlet height can be adjusted manually [mm] | 65-185 |
| | Hot water dispensing: left | s |
| | Hot water dispensing: central incl. additional water | o |
| | Additional water (Americano) | o |
| | Brewing accelerator (belongs to additional water) | o |
| | Single outlet | s |
| | Double outlet | s |
| Grinders and containers | 1 grinder | s |
| | 2 grinders | o |
| | Bean hopper [g] | ± 750 |
| | Ground coffee inlet | s |
| Boilers | One hot water boiler for coffee/tea | s |
| | Steam boiler | o |
| Milk systems | Pure Foam | o |
| | Side cooling unit on right or left (Soul Cooler approx. 6cm height difference to machine) | o |
| | Under-counter cooling unit (Soul Cooler) | o |
| Powder system | Powder container (g) (ml) | 2000/2750 |
| | Chocolate (1x Choco powder) | o |
| | Twin powder (2x 1000 g) | o |
| Other options | Grounds container (coffee grounds cake) | 550 g |
| | Undercounter grounds disposal | o |
| | High feet (40 mm) | o |
| | Schaerer Coffee Link | o |
| | Payment system (MDB, RS232 serial interface) | o |
| Colours | Red, Black | s |
| | Special colour | on request |
| Dimensions and weight | Width (mm) | 330 |
| | Depth (mm) | 576 |
| | Height body / incl. hopper / incl. key (mm) | 524 / 680 / 697 |
| | Weight (kg) (net) | Approx. 40 |
| Energy supply and power | 1L, N, PE: 220-240 V- 50/60 Hz | 2000-2400 W, 10 A, 3 x 1 mm ² |
| | 1L, N, PE: 200-220 V 2- 50/60 Hz | 1800-2200 W, 10 A, 3 x 1,5 mm ² |
| | 2L, PE: 200 V- 50/60H | 1800 W, 10 A, 3 x 1 mm ² |
| Water supply and disposal | Internal fresh water tank | s |
| | Mains water supply | o |
| | Waste water outlet | s |
| | External container for fresh and waste water | o |

s: Standard

o: Option



We love it *your way.*



Coffee competence

Our long established Coffee Competence is at your service, just call on us for any advice.



Flexibility

We support your business through our flexible offer, because we love it your way.



Swiss

As a Swiss technology company, we commit to impeccable quality and performance.

Headquarters

Schaerer Ltd.

Allmendweg 8
4528 Zuchwil
Switzerland
info@schaerer.com

Discover the worldwide Schaerer network and our comprehensive coffee expertise no matter where you are! With subsidiaries and partners in more than 70 countries in Europe, America, Africa, Asia and the Pacific region.

Find a contact near you:

[schaerer.com](https://www.schaerer.com)

Schaerer – a Groupe SEB Company

